

# Estimation of Temporary Overvoltages during Power System Restoration using Artificial Neural Network

Iman Sadeghkhan, Abbas Ketabi, *Associate Member, IEEE*, and Rene Feuillet, *Senior Member, IEEE*

**Abstract**—The energization of power transformers following a complete or partial collapse of the system is an important issue. This paper presents an Artificial Neural Network (ANN)-based approach to estimate the temporary overvoltages (TOVs) due to transformer energization. In proposed methodology, Levenberg-Marquardt second order method is used to train the multilayer perceptron. The developed ANN is trained with the extensive simulated results, and tested for typical cases. Then the new algorithms are presented and demonstrated for a partial of 39-bus New England test system. The simulated results show that the proposed technique can estimate the peak values and duration of switching overvoltages with good accuracy.

**Index Terms**—Artificial neural networks; harmonic overvoltages; power system restoration; transformer energization.

## I. INTRODUCTION

THE problem of restoring power systems after a complete or partial blackout is as old as the power industry itself. In recent years, due to economic competition and deregulation, power systems are being operated closer and closer to their limits. At the same time, power systems have increased in size and complexity. Both factors increase the risk of major power outages. After a blackout, power needs to be restored as quickly and reliably as possible and, consequently, detailed restoration plans are necessary [1], [2].

One of the major concerns, especially at the beginning of a system restoration, is related to temporary overvoltages. During the early stages of the restoration procedures following a partial or complete blackout of the power system, the system is lightly loaded and resonance conditions are different from the ones at normal operation.

The magnitude and shape of the switching overvoltages vary with the system parameters and network configuration. Even with the same system parameters and network configuration, the switching overvoltages are highly dependent on the characteristics of the circuit breaker operation and the point-on-wave where the switching operation takes place [3].

The reliable operation of any electrical power system is determined to a great extent by the amplitude, duration and

frequency of the transient voltages appearing in different places in the network. Power transformers, surge arresters and circuit breakers will be the equipment earliest affected by overvoltages. Transient overvoltages are usually a significant factor at transmission voltages above 400 kV. At higher transmission voltages, overvoltages caused by switching may become significant, because arrester operating voltages are relatively close to normal system voltage and lines are usually long so that the energy stored on the lines may be large. Overvoltage will put the transformer into saturation, causing core heating and copious harmonic current generation. Circuit breaker called upon to operate during periods of high voltage will have reduced interrupting capability. At some voltage even the ability to interrupt line-charging current will be lost [2].

In this paper power system blockset (PSB), a MATLAB/Simulink-based simulation tool [4] is used for computation of both switching and temporary overvoltages. This paper presents the artificial neural network (ANN) application for estimation of peak and duration overvoltages under switching transients during transformer energization. A tool such as proposed in this paper that can give the maximum switching overvoltage and its duration will be helpful to the operator. It can be used as training tool for the operators. The proposed ANN is expected to learn many scenarios of operation. To give the maximum peak overvoltage and its duration in a shortest computational time which is the requirement during online operation of power systems. In the proposed ANN we have considered the most important aspects, which influence the transient overvoltages such as source voltage, line length, switching angle, line capacitor, saturation curve slope and remanent flux. This information will help the operator to select the proper sequence of transformer to be energized safely with transients appearing safe within the limits. Results of the studies are presented for a partial of 39-bus New England test system to illustrate the proposed approach.

## II. MODELLING ISSUES

### A. PSB

Simulations presented in this paper are performed using the PSB. The simulation tool has been developed using state variable approach and runs in the MATLAB/Simulink environment. This program has been compared with other popular simulation packages (EMTP and Pspice) in [4]. The user friendly graphical interfaces of PSB enable faster development for power system transient analysis.

I. Sadeghkhan and A. Ketabi are with the Department of Electrical Engineering, University of Kashan, Kashan, Iran (e-mail: sadeghkhan@grad.kashanu.ac.ir, aketabi@kashanu.ac.ir).

R. Feuillet is with the Laboratoire d'Electrotechnique de Grenoble, INPG/ENSIEG, BP46, 38402 Saint Martin d'Hères, Cedex, France, (e-mail: rene.feuillet@leg.ensieg.inpg.fr).

### B. Transmission-Line Model

Transmission lines are described by PI cells, the  $R$ ,  $L$  and  $C$  parameters being derived from lumped-line models. One PI section is used for every 25 km line section [5].

### C. Generator Model

In [6], generators have been modeled by the generalized Park's model that electrical and mechanical parts are thoroughly modeled. In this work, generators are represented by a sinusoidal voltage source behind their subtransient reactances  $X_d''$ . Phases of voltage sources are determined by the load-flow results.

### D. Load and Shunt Devices Model

All of the loads and shunt devices, such as capacitors and reactors, are modeled as constant impedances.

### E. Transformer Model

The model takes into account the winding resistances ( $R_1$ ,  $R_2$ ), the leakage inductances ( $L_1$ ,  $L_2$ ) as well as the magnetizing characteristics of the core, which is modeled by a resistance,  $R_m$ , simulating the core active losses and a saturable inductance,  $L_{sat}$ . The saturation characteristic is specified as a piece-wise linear characteristic [7].

## III. HARMONIC OVERVOLTAGES DURING RESTORATION

One of the major concerns in power system restoration is the occurrence of overvoltages as a result of switching procedures. These can be classified as transient overvoltages, sustained overvoltages, harmonic resonance overvoltages, and overvoltages resulting from ferro-resonance. Steady-state overvoltages occur at the receiving end of lightly loaded transmission lines as a consequence of line-charging currents (reactive power balance). Excessive sustained overvoltages may lead to damage of transformers and other power system equipment. Transient overvoltages are a consequence of switching operations on long transmission lines, or the switching of capacitive devices, and may result in arrester failures. Ferro-resonance is a nonharmonic resonance characterized by overvoltages whose waveforms are highly distorted and can cause catastrophic equipment damages [2].

The energization of power transformers may create saturation of the transformer magnetic core and can lead to large harmonic temporary overvoltages due to high inrush currents [5]. This paper concentrates on the estimation of harmonic overvoltages. These are a result of network resonance frequencies close to multiples of the fundamental frequency. They can be excited by harmonic sources such as saturated transformers, power electronics, etc. They may lead to long lasting overvoltages resulting in arrester failures and system faults [1].

The major cause of harmonic resonance overvoltage problems is the switching of lightly loaded transformers at the end of transmission lines. The harmonic-current components

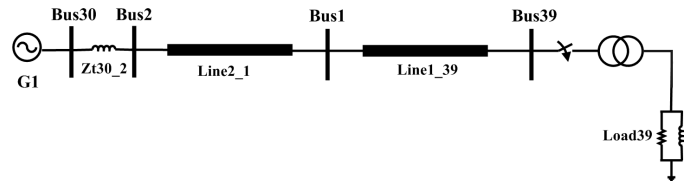

Figure 1. Power system at the beginning of a restoration procedure.

of the same frequency as the system resonance frequencies are amplified in case of parallel resonance, thereby creating higher voltages at the transformer terminals. This leads to a higher level of saturation, resulting in higher harmonic components of the inrush current that again results in increased voltages. This can happen particularly in lightly damped systems, common at the beginning of a restoration procedure when a path from a black-start source to a large power plant is being established and only a few loads are restored yet [2], [8].

The sample system considered for explanation of the proposed methodology is a 400 kV EHV network shown in Fig. 1. This is portion of 39-bus New England test system. The normal peak value of any phase voltage is  $400\sqrt{2}/\sqrt{3}$  kV and this value is taken as base for voltage p.u. In the system studies 400 kV line-to-line base voltage and 100 MVA as a base power is considered. Fig. 2 shows the switching transient at bus 39 when transformer is energized.

In practical system a number of factors affect the overvoltages factors due to energization or reclosing. In this paper following parameters is considered:

- Source voltage
- Line length
- Line capacitor
- Closing time of the circuit breaker poles
- Saturation curve slope
- Remanent flux

Source voltage affect the overvoltage strongly. Fig. 3 shows the effect of source voltage on overvoltage at different saturation curve slope. The saturation curve, and especially the  $L_{sat}$  i.e. the final slope of this curve, is a key point for the computation of the inrush currents but is not very easy to

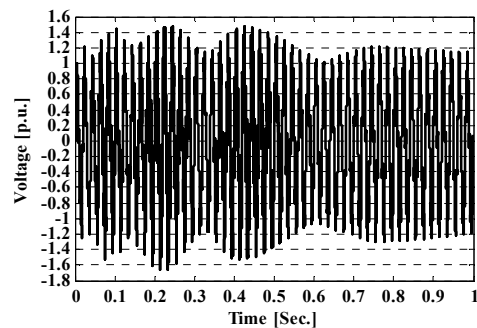

Figure 2. Voltage at bus 39 after switching of transformer.

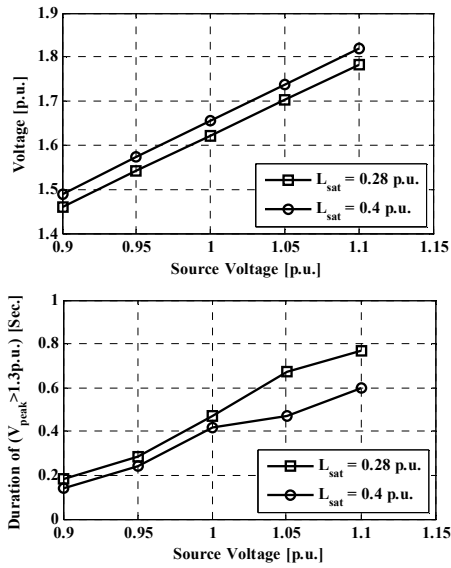

Figure 3. Overvoltage peak and duration at bus 39 as source voltage while line length 100 km, line capacitor 1.237e-8, switching angle 18° and remanent flux 0.8 p.u.  $L_{sat}$  is saturation curve slope.

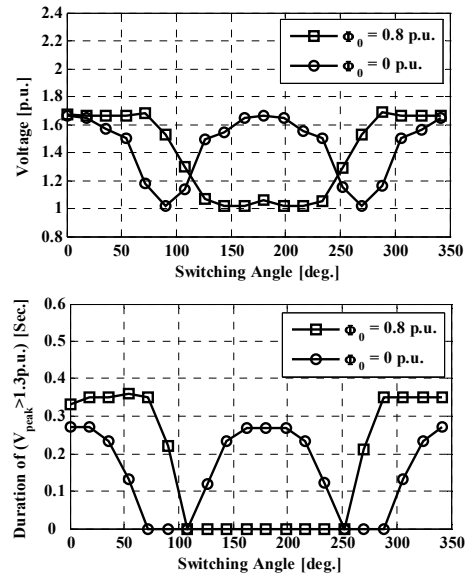

Figure 5. Overvoltage peak and duration at bus 39 as switching angle while source voltage 1 p.u., line length 100 km, line capacitor 1.237e-8 and saturation curve slope 0.32 p.u.  $\Phi_0$  is remanent flux.

obtain. The transformer manufacturer provides a  $L_{sat}$  slope value with a dispersion usually considered of  $\pm 20\%$ . Fig. 4 shows the effect of line length on overvoltages at different source voltage. Controlled switching of high-voltage ac circuit breakers has become a commonly accepted means of controlling switching transients in power systems. Fig. 5 shows effect of switching angle on overvoltages at different remanent flux. Fig. 6 shows the effect of line capacitor on overvoltages at different switching angle.

As discussed above for an existing system the main factors witch affect the peak and duration values of switching

overvoltage are source voltage, line length, line capacitor, switching angle, saturation curve slope and remanent flux. Here it should be mentioned that a single parameter often cannot be regarded independently from the other important influencing factors. The magnitude and duration of the overvoltages normally does not depend directly on any single isolated parameter and a variation of one parameter can often alter the influence of another parameter, in other words there exists an interaction between the various system and breaker parameters. This forbids the derivation of precise generalized rule of simple formulae applicable to all cases [9]. So an ANN

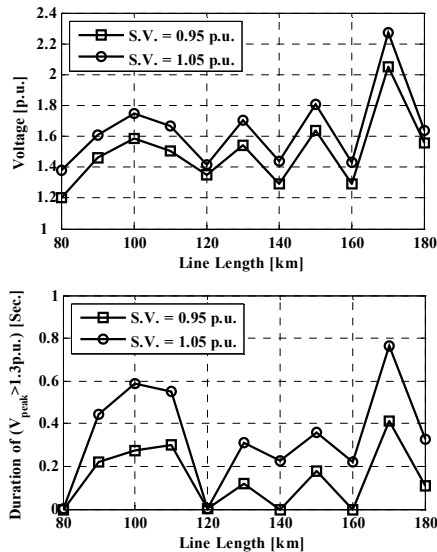

Figure 4. Overvoltage peak and duration at bus 39 as line length while line capacitor 1.237e-8, switching angle 18°, saturation curve slope 0.32 p.u. and remanent flux 0.8 p.u. S.V. is source voltage.

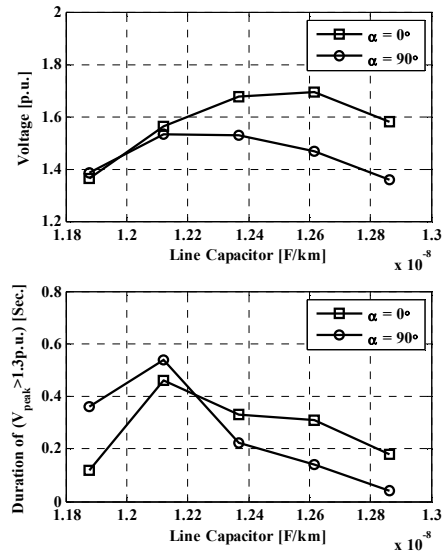

Figure 6. Overvoltage peak and duration at bus 39 as line capacitor while source voltage 1 p.u., line length 100 km, saturation curve slope 0.32 p.u. and remanent flux 0.8 p.u.  $\alpha$  is switching angle.

can help to estimate the peak and duration values of switching overvoltages generated during transformer energization.

#### IV. THE ARTIFICIAL NEURAL NETWORK

The proposal in this work considers the adoption of feed forward Multilayer Perceptron (MLP) architecture. The schematic diagram of the proposed MLP neural networks architecture is shown in Fig. 7. The composition of the input variables for the proposed neural networks has been carefully selected.

Supervised training of ANN is a usual training paradigm for MLP architecture. Fig. 8 shows the supervised learning of ANN for which input is given to PSB to get the peak and duration values of transient overvoltages and the same data is used to train the ANN. Error is calculated by the difference of PSB output and ANN output. This error is used to adjust the weight of connection. Output values of the trained neural networks must be capable of computing the voltages with very good precision. Gradient-based training algorithms, like back propagation, are most commonly used for training procedures. They are not efficient due to the fact that the gradient vanishes at the solution. Hessian-based algorithms allow the network to learn more subtle features of a complicated mapping. The training process converges quickly as the solution is approached, because the Hessian does not vanish at the solution. To benefit from the advantages of Hessian based training, we focused on the Levenberg–Marquardt (LM) algorithm reported in [10].

##### A. Levenberg-Marquardt (LM) Algorithm

Suppose that we have a function  $\xi(\mathbf{x})$  which we want to minimize with respect to the parameter vector  $\mathbf{x}$ , where

$$\xi(\mathbf{x}) = \sum_{i=1}^N e_i^2(\mathbf{x}) \quad (1)$$

Then the Marquardt–Levenberg modification to the Gauss–Newton method is

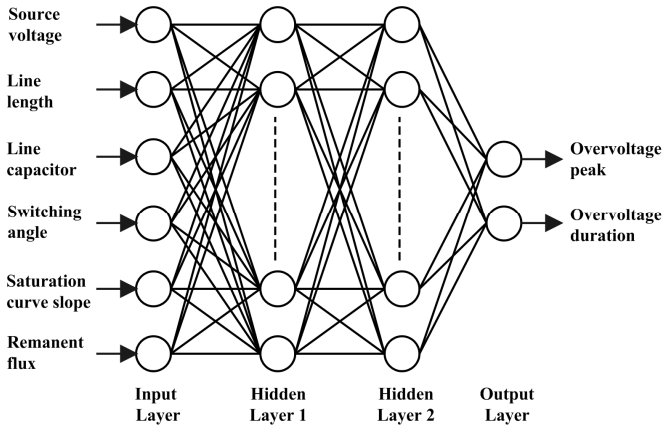

Figure 7. Proposed MLP-based ANN architecture.

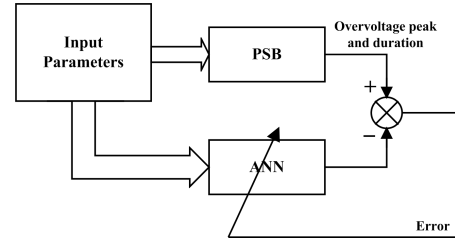

Figure 8. Supervised learning of ANN.

$$\Delta \mathbf{x} = [\mathbf{J}^T(\mathbf{x})\mathbf{J}(\mathbf{x}) + \mu\mathbf{I}]^{-1}\mathbf{J}^T(\mathbf{x})\mathbf{e}(\mathbf{x}) \quad (2)$$

The parameter  $\mu$  is multiplied by some factor  $\beta$  whenever a step would result in an increased  $\xi(\mathbf{x})$ . When a step reduces  $\xi(\mathbf{x})$ ,  $\mu$  is divided by  $\beta$ . Notice that when  $\mu$  is large the algorithm becomes steepest descent; while for small  $\mu$  the algorithm becomes Gauss–Newton.

One of the most critical problems in constructing the ANN is the choice of the number of hidden layers and the number of neurons. In this study, a MLP with two hidden layer and 10 hidden units per layer is found to be sufficient to get good accuracy and generalization for proposed scheme. A large number of testing data have been used to check the proposed solution in the most objective way at practically all possible parameters variation. percentage error are calculated as:

$$\text{error}(\%) = \frac{|\text{ANN} - \text{PSB}|}{\text{PSB}} \times 100 \quad (3)$$

#### V. CASE STUDY

In this section, the proposed algorithm is demonstrated for two case studies that are a portion of 39-bus New England test system, of which its parameters are listed in [11]. The simulations are undertaken on a single phase representation.

##### A. Case 1

Fig. 1 shows a one-line diagram of a portion of 39-bus New England test system which is in restorative state. The generator at bus 30 is a black-start unit. The load 1 shows cranking power of the later generator that must be restored by the transformer of bus 39. When the transformer is energized, harmonic overvoltages can be produced because the transformer is lightly loaded. Neural network is trained with the goal of mean square error (MSE)  $1e-3$ . Fig. 9 shows the training of neural network. Results for a sample test data are presented in Table I and also shown in Figs. 10–11. Table I contains the some sample result of test data of case 1. Values in column  $V_{\text{PSB}}$  are the absolute values of peak voltage at bus 39 calculated by PSB program where the  $V_{\text{ANN}}$  values are the values simulated by trained network. Also Values in column  $T_{\text{PSB}}$  are the values of overvoltage duration calculated by PSB program and  $T_{\text{ANN}}$  values are the values simulated by trained network. Fig.10 shows overvoltage peak and duration at bus

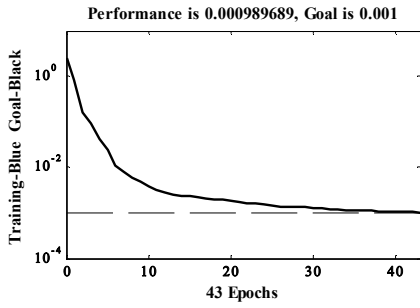

Figure 9. Squared error against epoch curve.

39 against the source voltage and Fig.11 shows overvoltage peak and duration at bus 39 against the line capacitor.

### B. Case 2

As another example, the system in Fig. 12 is examined. It represents the same system as the one in Fig. 1, but a few restoration steps later. In the next step of the restoration, unit at bus 29 must be restarted. In order to provide cranking power for this unit, the transformer at bus 29 should be energized. In this condition, harmonic overvoltages can be produced because the load of the transformer is small. The various cases of transformer energization are taken into account and corresponding peak and duration overvoltages are computed from PSB program. Summary of few result are presented in Table II. it can be seen from the results that the ANN is able to learn the pattern and give results to acceptable accuracy.

## VI. CONCLUSION

A Neural Network approach to estimate the peak and duration overvoltages due to transformer energization is proposed and implemented. The Levenberg–Marquardt second order training method has been adopted for obtaining small mean square error (MSE) without losing generalization capability of ANN. The results from this scheme are close to results from the conventional method and helpful in predicting the overvoltage of the other case studies within the range of

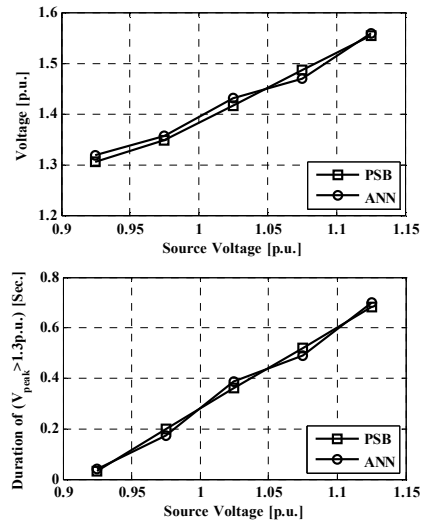

Figure 10. ANN output: overvoltage peak and duration at bus 39 simulated by ANN and PSB while line length 125 km, line capacitor 1.237e-8, switching angle 18°, saturation curve slope 0.38 p.u. and remanent flux 0.8 p.u.

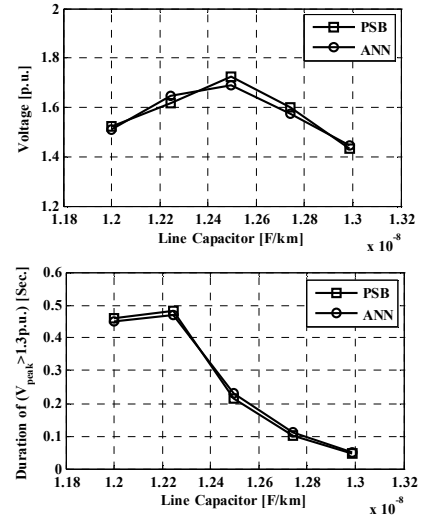

Figure 11. ANN output: overvoltage peak and duration at bus 39 simulated by ANN and PSB while source voltage 1 p.u., line length 100 km, switching angle 45°, saturation curve slope 0.32 p.u. and remanent flux 0.3 p.u.

TABLE I. CASE 1 SOME SAMPLE TESTING DATA AND OUTPUT

S.V.	L.L.	C <sub>Line</sub>	S.A.	L <sub>sat</sub>	Φ <sub>0</sub>	V <sub>PSB</sub>	V <sub>ANN</sub>	error <sub>V</sub>	T <sub>PSB</sub>	T <sub>ANN</sub>	error <sub>T</sub>
0.975	85	1.237e-8	18	0.34	0.8	1.3168	1.3309	1.0708	0.0821	0.0838	2.0706
1.025	155	1.237e-8	18	0.26	0.8	1.802	1.8031	0.0610	0.288	0.2838	1.4583
1.075	95	1.224e-8	81	0.24	0.5	1.4357	1.4538	1.2607	0.0314	0.0308	1.9108
1	100	1.249e-8	333	0.32	0.1	1.7137	1.7316	1.0445	0.2209	0.2253	1.9919
1	100	1.274e-8	135	0.32	0.5	1.3302	1.3218	0.6315	0.1006	0.1027	2.0875
0.925	145	1.249e-8	315	0.34	0.3	1.7155	1.6420	4.2845	0.2211	0.2278	3.0303
1.125	125	1.237e-8	18	0.3	0.8	2.0995	2.0770	1.0717	0.6261	0.6372	1.7729
0.975	165	1.274e-8	99	0.3	0.7	1.6830	1.6734	0.5704	0.4406	0.4365	0.9305
0.925	185	1.237e-8	18	0.42	0.8	1.3556	1.3192	2.6852	0.0532	0.0515	3.1955
1	100	1.224e-8	63	0.32	0.3	1.6175	1.6094	0.4997	0.3828	0.3804	0.6270
1.025	125	1.199e-8	9	0.36	0.1	1.4737	1.5204	3.1689	0.4584	0.4489	2.0724
1	100	1.298e-8	81	0.32	0.3	1.3294	1.3391	0.7297	0.5282	0.5152	2.4612
1.075	115	1.237e-8	18	0.42	0.8	1.7091	1.7201	0.6436	0.4008	0.4073	1.6218
1.1	185	1.298e-8	225	0.4	0.1	1.5812	1.5985	1.0941	0.1404	0.1462	4.1311
1	100	1.199e-8	27	0.32	0.7	1.5228	1.5443	1.4119	0.3424	0.3488	1.8692

S.V. = source voltage [p.u.], L.L. = line length [km], C<sub>Line</sub> = line capacitor [F/km], S.A. = switching angle [deg.], L<sub>sat</sub> = saturation curve slope [p.u.], Φ<sub>0</sub> = remanent flux [p.u.], error<sub>V</sub> = voltage error [%] and error<sub>T</sub> = duration time error [%].

TABLE II. CASE 2 SOME SAMPLE TESTING DATA AND OUTPUT

S.V.	L.L.	C <sub>Line</sub>	S.A.	L <sub>sat</sub>	Φ <sub>0</sub>	V <sub>PSB</sub>	V <sub>ANN</sub>	error <sub>v</sub>	T <sub>PSB</sub>	T <sub>ANN</sub>	error <sub>T</sub>
0.925	125	1.237e-8	18	0.3	0.8	1.7582	1.7442	0.7927	0.7619	0.7737	1.5488
1.025	155	1.237e-8	18	0.38	0.8	2.0927	2.0539	1.8502	0.5208	0.5248	0.7680
0.975	105	1.199e-8	45	0.26	0.5	1.5777	1.5921	0.9127	0.7325	0.7451	1.7201
0.925	175	1.224e-8	9	0.34	0.7	1.8827	1.8670	0.8339	0.2432	0.2425	0.2878
1	100	1.298e-8	27	0.32	0.5	1.6269	1.5963	1.8813	0.5019	0.5071	1.0361
1	100	1.249e-8	81	0.32	0.3	1.7393	1.7385	0.0460	0.6133	0.6097	0.5870
1.075	115	1.298e-8	45	0.3	0.5	2.0174	2.0347	0.8575	0.8971	0.9094	1.3711
1.025	95	1.274e-8	63	0.38	0.8	1.6562	1.6233	1.9865	0.7413	0.7499	1.1562
1.025	135	1.199e-8	81	0.26	0.3	2.2442	2.2346	0.4278	0.5821	0.5891	1.2025
1	100	1.224e-8	9	0.32	0.7	1.6577	1.6476	0.6086	0.7614	0.7532	1.0734
1.075	175	1.237e-8	18	0.26	0.8	2.2313	2.1638	3.0251	0.5143	0.5238	1.8472
0.925	145	1.249e-8	27	0.38	0.1	1.9880	1.9375	2.5402	0.3413	0.3458	1.3185
0.975	115	1.274e-8	81	0.34	0.8	1.7756	1.8195	2.4724	0.5976	0.5923	0.8869
1	100	1.199e-8	45	0.32	0.1	1.6615	1.6638	0.1384	0.6843	0.6909	0.9645
0.975	85	1.249e-8	63	0.38	0.1	1.4301	1.4524	1.5593	0.5204	0.5146	1.1145

S.V. = source voltage [p.u.], L.L. = line length [km], C<sub>Line</sub> = line capacitor [F/km], S.A. = switching angle [deg.], L<sub>sat</sub> = saturation curve slope [p.u.], Φ<sub>0</sub> = remanent flux [p.u.], error<sub>v</sub> = voltage error [%] and error<sub>T</sub> = duration time error [%].

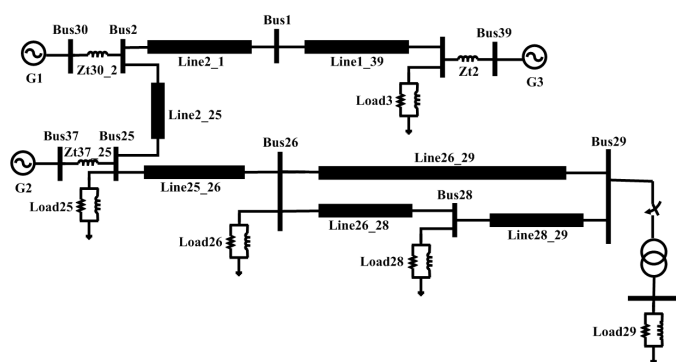

Figure 12. Studied system for case 2.

training set. The proposed ANN approach is tested on a partial 39-bus New England test system. The ANN application can be used an operator-training tool for estimation of temporary overvoltages during power system restoration.

## REFERENCES

- [1] A. Ketabi, A.M. Ranjbar, and R. Feuillet, "Analysis and Control of Temporary Overvoltages for Automated Restoration Planning," *IEEE Trans. Power Delivery*, vol. 17, pp. 1121–1127, Oct. 2002.
- [2] M. M. Adibi, R.W. Alexander, and B. Avramovic, "Overvoltage control during restoration," *IEEE Trans. Power Syst.*, vol. 7, pp. 1464–1470, Nov. 1992.
- [3] D. Thukaram, H.P. Khincha, and Sulabh Khandelwal, "Estimation of switching transient peak overvoltages during transmission line energization using artificial neural network," *Electric Power System Research*, 76 (2006) pp. 259–269.
- [4] G. Sybille, P. Brunelle, L. Hoang, L. A. Dessaint, and K. Al-Haddad, "Theory and applications of power system blockset, a MATLAB/Simulink-based simulation tool for power systems," in *Proc. IEEE Power Eng. Soc. Winter Meeting*, pp. 774–779.
- [5] F. Zgainski, B. Caillault, and V. Renouard, "Validation of power plant transformers re-energization schemes in case of black-out by comparison between studies and field tests measurements," in *Proc. International Conference on power systems Transients*, 2007.
- [6] P. G. Boliaris, J. M. Prousalidis, N. D. Hatzargyriou, and B. C. Papadias, "Simulation of long transmission lines energization for black start studies," in *Proc. 7th Mediterranean Electrotechn.Conf.*, 1994, pp. 1093–1096.

- [7] G. Sybille, M. M. Gavrilovic, J. Belanger, and V. Q. Do, "Transformer saturation effects on EHV system overvoltages," *IEEE Trans. Power App. Syst.*, vol. PAS-104, pp. 671–680, Mar. 1985.
- [8] G. Morin, "Service restoration following a major failure on the hydroquebec power system," *IEEE Trans. Power Delivery*, vol. 2, pp. 454–463, Apr. 1987.
- [9] Cigre Working Group, "Switching overvoltages in EHV and UHV systems with special reference to closing and reclosing transmission lines," *Electra* 30 (1973) pp. 70–122.
- [10] M.T. Hagan and M.B. Menhaj, "Training feedforward networks with the Marquardt algorithm," *IEEE Trans. Neural Network*, vol.5, pp. 989-993, Nov. 1994.
- [11] S. Wunderlich, M. M. Adibi, R. Fischl, and C. O. D. Nwankpa, "An approach to standing phase angle reduction," *IEEE Trans. Power Syst.*, vol. 9, pp. 470–478, Feb. 1994.



**Iman Sadeghkhani** received the B.Sc. degree with honor in Electrical Engineering from Department of Electrical Engineering, IAU-Najafabad Branch, Isfahan, Iran in 2007. Currently, he is pursuing his M.Sc degree in Electrical Engineering from Department of Electrical Engineering, University of Kashan, Kashan, Iran. His research interests are power system restoration, transient studies, and artificial intelligence applications in power systems.



**Abbas Ketabi** received the B.Sc. and M.Sc. degrees in electrical engineering from the Department of Electrical Engineering, Sharif University of Technology, Tehran, Iran, in 1994 and 1996, respectively. He received the Ph.D. degree in electrical engineering jointly from Sharif University of Technology and the Institut National Polytechnique de Grenoble (INPG), Grenoble, France, in 2001. His research interests are power system restoration, expert systems, and transient studies.



**Rene Feuillet** received the Ph.D. degree in electrical engineering from Institut National Polytechnique de Grenoble, Grenoble, France, in 1979. He also received the Habilitation a Diriger des Recherches degree from the same institute in 1991. Currently, he is Full Professor with the National Electrical Engineering School of Grenoble (ENSIEG), Grenoble, France. His research activities include modeling of power electronics converters and interference perturbations

on power networks and components.